

FTIR Monitoring of the Ventilation Air of Critical Buildings

Paper # 1274

Dr. Scott E. McLaren

PM Tech Inc.

6355 Ward Road, Suite 300

Arvada, CO 80004

PMT9999@aol.com

Kevin M. Fisher

Apogee Scientific, Inc.

2895 W. Oxford Ave., Suite 1

Englewood, CO 80110

Dr. Bruce Harris

U.S. Environmental Protection Agency

ORD, National Risk Management Research Laboratory

109 T.W. Alexander Drive, E343-02

Research Triangle Park, NC 27711

Abstract

Fourier transform infrared (FTIR) spectroscopy has been used for detailed analysis of environmental and industrial process samples for many years. The FTIR has the capability of measuring multiple compounds simultaneously, thus providing an advantage over most other measurement methods which measure only one or several compounds. In addition, FTIR can be configured to operate unattended over long periods of time, produces data in real time, and generates no chemical waste. With the effort of the Nation being concentrated upon the protection of its citizens from terrorist attacks using chemical agents and poisonous industrial compounds, the ability of FTIR to analyze for many compounds quickly, simultaneously, and with little operator intervention makes it an attractive choice for Homeland Security monitoring situations.

A project has begun to employ FTIR spectroscopy for monitoring the ventilation air of critical buildings. In Task 1, a guidance document has been developed for State and Local Homeland Security planners and first responders which describes the availability and performance of existing FTIR systems which can be used for Homeland Security. Guidance is provided to aid people in making an informed decision when selecting FTIR instrumentation for their security needs. In Task 2, a commercial FTIR system will be configured, installed, and demonstrated as an air inlet monitor for a large building ventilation system. In Task 3, a compact FTIR system mounted on a remotely piloted vehicle for building contamination investigations will be developed and demonstrated. The elements of each task will be presented as well as the progress to date.

Introduction

With the focus of the Nation on protecting its citizens from terrorist acts, attention must be given to the buildings in which people live and work. The ventilation system of a building acts as a perfect distribution system for toxic aerosols or vapors. The implications are that through a single point attack, a terrorist act could kill or maim the entire population of a medium to large building. Defending and protecting building ventilation systems from being co-opted into weapons of mass destruction must be addressed.

While modification and protection of ventilation system inlets will provide a certain measure of defense, a determined individual or group will always find a way to circumvent static defenses. The answer for high profile target structures is to include a real-time monitoring device capable of quickly detecting a myriad assortment of Chemical Warfare Agents (CWAs) and Toxic Industrial Compounds (TICs). The monitoring system provides an active defense against determined terrorist attacks on building ventilation systems. Technology is available that can detect and respond to a wide assortment of CWAs and TICs that could be introduced into a ventilation system in the form of a terrorist attack.

Fourier Transform Infrared (FTIR) spectroscopy has been used for the detailed analysis of environmental and industrial process samples for many years. The technology has the capability of measuring multiple compounds simultaneously, thus providing an advantage over most other measurement methods. In addition FTIR technology can be configured to operate unattended for long periods of time, provide a real-time data stream, and creates no chemical waste. The technology is capable of providing accurate data in a timely fashion that will enable an active system to manage a ventilation system in the event of a terrorist strike.

EPA is funding a project to employ FTIR spectroscopy technology for monitoring the ventilation air of critical or high profile buildings. In the first task of the project, a guidance document has been developed for State and Local Homeland Security planners and first responders, as well as building operators, which describes the availability and performance of existing FTIR technology. The guidance document focuses on the use of FTIR technology as an active defense measure to be employed in critical building ventilation systems. In addition, a commercially available FTIR system will be configured, installed, and demonstrated as an air inlet monitor for a large building ventilation system. The final task is to develop and demonstrate a compact FTIR system to be mounted on a remotely piloted vehicle for building contamination investigations.

Background

FTIR Technology

FTIR spectroscopy is a proven measurement technique that is capable of detecting multiple compounds simultaneously. FTIR absorption spectroscopy is based on the principle that almost all molecules absorb infrared light. Only the monatomic (He, Ne,

etc.) and the homopolar diatomic (N_2 , O_2 , Cl_2 , F_2 , etc.) do not absorb infrared light. A molecule will only absorb infrared light at particular wavelength, depending on physical properties of the molecule. The pattern of infrared light absorption as a function of wavelength is unique to each molecule and can be used as a fingerprint to identify the molecule. The magnitude of the light absorption is a function of the number of molecules in the light beam and can be used to determine the concentration of analyte molecules.

FTIR absorption spectroscopy is a very universal analysis technique. Practically all gases, with the exception of monatomic and homopolar diatomic gases, have absorption bands in the $700 - 5000\text{ cm}^{-1}$ spectral region and can be detected by FTIR spectrometry. The only gases of concern in building protection that cannot be detected by FTIR spectroscopy are the halogen gases: chlorine (Cl_2), fluorine (F_2), and bromine (Br_2). Chlorine and fluorine are classified as high hazard index TICs while bromine is classified as a low hazard index TIC. While Cl_2 and F_2 cannot be directly measured by FTIR spectroscopy, these gases hydrolyze very quickly in ambient air to form HCl and HF respectively. HCl and HF are both easily measured by FTIR spectroscopy and can be used as a surrogate for the measurement of Cl_2 and F_2 . Br_2 does not hydrolyze in ambient air and will not form a surrogate gas that can be detected by FTIR spectroscopy. Br_2 is not as toxic or as readily available as Cl_2 or F_2 , thus it is not likely to be used by a terrorist in an attack. If it is decided that Cl_2 , F_2 , and Br_2 need to be monitored directly, a supplemental detector for these gases could be employed. Detectors that can be used to monitor for Cl_2 , F_2 , and Br_2 are currently commercially available

FTIR spectrometers are composed of a light source, an interferometer, a detector, and the supporting computer and software. For this particular application choosing a piece of equipment from a reputable vendor ensures that the physical equipment will be capable and dependable. Specific consideration must be given to the resolution of the interferometer and the spectral range of the detector. For this application a resolution of 4 cm^{-1} (wave numbers) is required, and a detector capable of detection across the entire spectral range is needed.

The supporting computer and software are the biggest consideration in choosing an FTIR spectrometer for this application. Software is what enables the use of FTIR spectrometry to detect and measure chemical compounds. For this application software will be needed that can identify dangerous and suspect chemical spectra quickly and reliably. There will be hundreds of chemical compounds and spectral signatures that need to be parsed for each individual scan. Figure 1 shows FTIR spectras for ammonia, Mustard Gas, Sarin, and Sulfur Hexafluoride (SF_6). The Figure demonstrates both the unique signature and character that individual chemical compounds possess, as well as, the need for detectors that cover the entire IR spectral range.

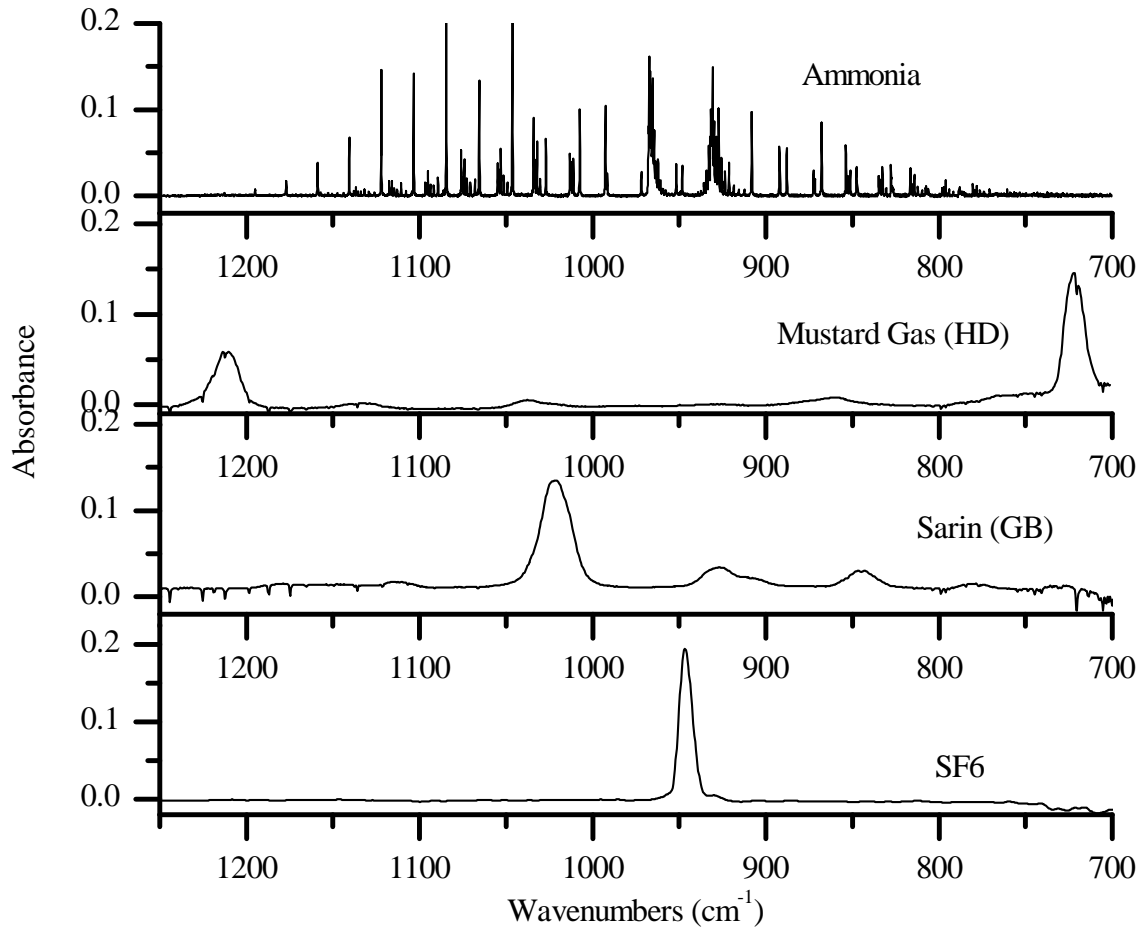

Figure 1. IR Spectra

Chemical Warfare Agents and Toxic Industrial Compounds

There are two distinct groups of chemicals likely to be employed by a terrorist to attack the ventilation system of a target building. Chemical warfare agents (CWAs) are chemical compounds significant for their toxicity and lethality to people. Toxic Industrial Compounds (TICs) are chemical compounds found in everyday industrial applications, such as chlorine or ammonia that have significant toxicity and health impacts.

CWAs are chemicals that have been developed and produced over the years as part of military weapons systems. Including chemical agents such as Mustard Gas, Sarin, VX-gas, and others. These compounds have varying chemical properties and manufacture methods. As such the two that are the most concerning from a building defense perspective are Mustard Gas and Sarin because of their relatively high volatility (more likely to vaporize and carry through the air) and their ease of manufacture. Most other CWAs are either not highly volatile, or difficult and dangerous to manufacture.

TICs are chemical compounds that are widely available and used in the everyday practices of various industries. Chemical compounds such as ammonia or chlorine gas have multiple and varied uses throughout our society and yet are potentially as lethal as

any military chemical weapon. There are literally hundreds of different chemical compounds in use everyday that could be used as lethal chemical weapons to attack buildings. The International Task Force 25 has compiled a list of these everyday industrial compounds and has classified the compounds into three risk categories based on a variety of factors, such as volatility, toxicity, and availability. The complete listing of the different categories of TICs is provided in the guidance document that was developed for EPA as part of this program.

FTIR For Building Protection

To employ FTIR systems for protection of buildings from a terrorist attack the system must be incorporated into an already complicated ventilation and life-support system. Simply placing an FTIR system without full integration to the rest of the building will not accomplish anything. The system must be properly sited to maximize detection probability and fully integrated into the ventilation control system to achieve any appreciable defense function. In addition modifications and additions will likely need to be made to a ventilation system to take full advantage of the FTIR detector. Figure 2 shows the envisioned placement and integration of an FTIR system into building systems to actively defend the building from terrorist chemical attacks.

It is envisioned that an FTIR detection system would be placed in service at the inlet to the air-handling unit (AHU) for a building or particular ventilation system. Sited at this location the unit could detect any threat whether from a release in the external air inlet or a release within the building. The concentrations detected by the unit would vary remarkably depending on the type of release and therefore differing defense actions would be carried out. In the case of a release in the external air inlet concentrations of the hazardous chemical would be high, whereas for a release inside the building, concentrations would be low due to dilution.

Integrating the support computer into the control systems for a buildings ventilation system will be required due to the nature of the modern ventilation systems. An automated response from the system is required because of the air velocities and residence times typical of ventilation systems. Air passing through an AHU could take as little as a couple of seconds to reach inhabited and vulnerable spaces of a building, making automated response the only choice. An additional problem is the nature of air handling equipment. Most blowers used in ventilation systems are not capable of quickly stopping, due to their size and speed of operation blowers can take in upwards of several minutes to completely stop, and while in the process of slowing to a stop the blower still moves contaminated air into occupied building spaces. Ventilation dampers present a similar problem in that they do not, typically, move quickly nor do they offer positive seals. This means that modifications to a building's ventilation system are warranted to provide the active defense capability offered by an FTIR system.

The addition of fast-acting dampers to supply ducts into occupied spaces solves the problem of the ventilation system pushing contaminated air into inhabited areas. However, the overpressure created by closing off the air outlets of the ventilation system would cause a catastrophic failure of the building's ductwork. Therefore, the addition of

a supply-side exhaust duct with a fast acting damper is also necessary. In the event of a positive detection of a CWA or TIC the FTIR system would send an alarm signal to the building ventilation system, which would cause the system to close the fast-acting dampers on the air supply ducts and open the supply-side exhaust. This would allow the ventilation system to vent the contaminated air into the atmosphere in a manner that would prevent exposure to building occupants or other individuals. In addition this type of system would continue to pull air from occupied areas of the building via the return air system in the case of a release inside the building. In the case of a false-positive event there has been no damage to the ventilation system and as long as the system is restored within 30 minutes to an hour the building occupants will likely not be affected.

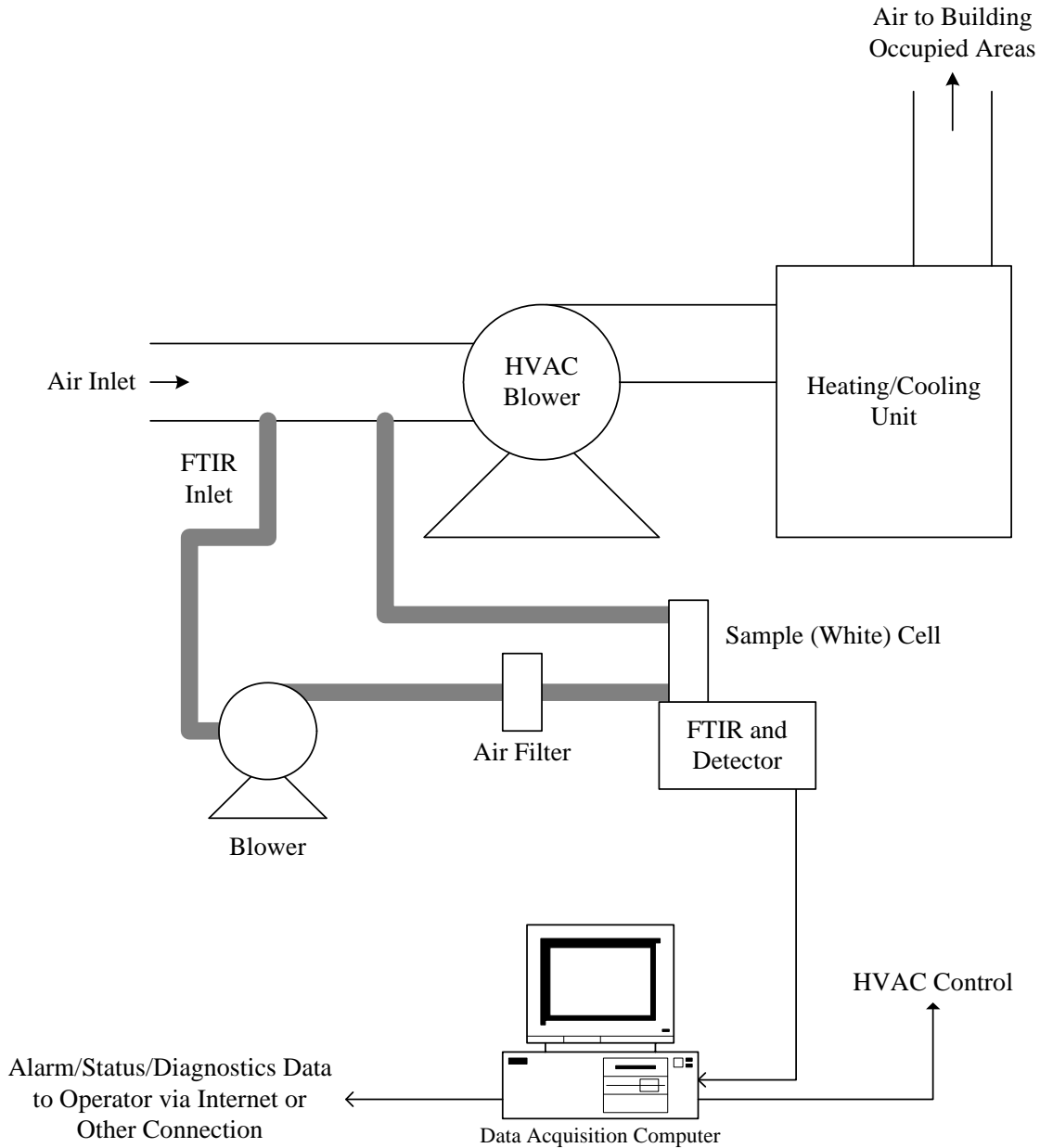

Figure 2. FTIR System Placement and Configuration

Project Progress

The project being funded by the EPA to assess the use of FTIR equipment for the defense of building ventilation systems is already underway. The project encompasses three different tasks:

- Task 1: Guidance Document
- Task 2: Configuration and Demonstration of FTIR for Building Protection
- Task 3: Configuration and Demonstration of FTIR for Remotely Piloted Vehicles for Use in Contamination Investigations

A guidance document on the selection and implementation of FTIR technology for building defense has been prepared and submitted to EPA. Please contact the authors for information regarding this document .

Starting in the spring of 2005, FTIR equipment will be purchased and configured to operate as a ventilation system detector. This system will be placed in service in the ventilation system of a medium to large occupancy building. The unit will be tested with appropriate CWA simulants and TICs to demonstrate the use of FTIR for building protection.

Following the conclusion of the building demonstration, the unit will be modified to be mounted on a remotely piloted vehicle (RPV), similar to a bomb-sniffing robot. The unit will be demonstrated in conjunction with an RPV for the purpose of carrying out investigations of potentially contaminated spaces and buildings.

Conclusion

The active defense of medium to high occupancy buildings from terrorist attacks is a serious concern. FTIR technology is capable of being employed as an active defense for building ventilation systems that might be the target of terrorist attacks. FTIR is a proven detection method that has been used in laboratory and field settings for many years. Adapting the technology to this application will require testing and development, but the technology is capable of meeting the needs of this application.

References

Key Words